

O3ONIA

**ONE YEAR FULL-SCALE STUDY
OF OZONE COOLING WATER TREATMENT
AT A GERMAN ELECTRIC POWER STATION**

ONE YEAR FULL-SCALE STUDY OF OZONE COOLING WATER TREATMENT AT A GERMAN ELECTRIC POWER STATION

Pierre A. Liechti and Dr. Rüdiger Kaulbach

Ozonia Ltd
Duebendorf, Switzerland

Abstract

This paper presents the operating results of ozone treatment of the water in a cooling system with an open loop containing the following elements:

- Main cooling water pumps
- Cooling water storage tanks
- Distribution manifold to cooling water users
- Cooling water collecting basins
- Cooling water recycling pumps
- Cooling tower

The system reviewed in this paper is the side stream cooling system of a power station in Germany, with a capacity of 1000 m³/h (4400 US gpm). Operation started in early 1989 and the plant was operated for over 2 years. During this period the following items were analyzed and evaluated:

- Ozone residual in the water
- Quality of the cooling water
- Organic scaling on equipment and piping
- Material corrosion

For the purpose of analyzing the corrosion, two heat exchangers were installed, with identical ratings but each fitted with tubes of different materials. One unit was in contact with ozonated water, while the other was exposed to water without ozone.

The results of this study are extremely encouraging. The following paper reviews the findings of the 2 year operation.

Introduction

Over a period of approximately two years, up to the end of 1988, Asea Brown Boveri (ABB) carried out tests with ozone as a biocide on the water of a small industrial cooling tower at an ABB factory in Turgi, Switzerland. The positive results and experience of this experiment were the driving force behind the idea to test the application of ozone in a larger cooling water system.

In 1988, an ozonation plant was installed on the side stream cooling water system of a power station in Germany. The experimental cooling system with ozone treated water operated on a more or less continuous basis starting in February 1989.

Description of the Side Stream Cooling Water System

The side stream cooling water system (Figure 1) consists of the following:

- One cooling water recovery tank, collecting the return cooling water discharged from the users
- One pumping station working the recovered cooling water to the top of the cooling tower
- Off that line, an ozone free cooling water side stream flows through the test heat exchanger 2
- One forced draft cooling tower. Ozone is added to the cooling tower bottom tank
- One pumping station working the cooled cooling water to the cooling water storage tanks
- Off this line, a side stream of ozonated cooling water flows through the test heat exchanger 1
- From the cooling water storage tanks, a distribution manifold distributes the cooling water to the different users

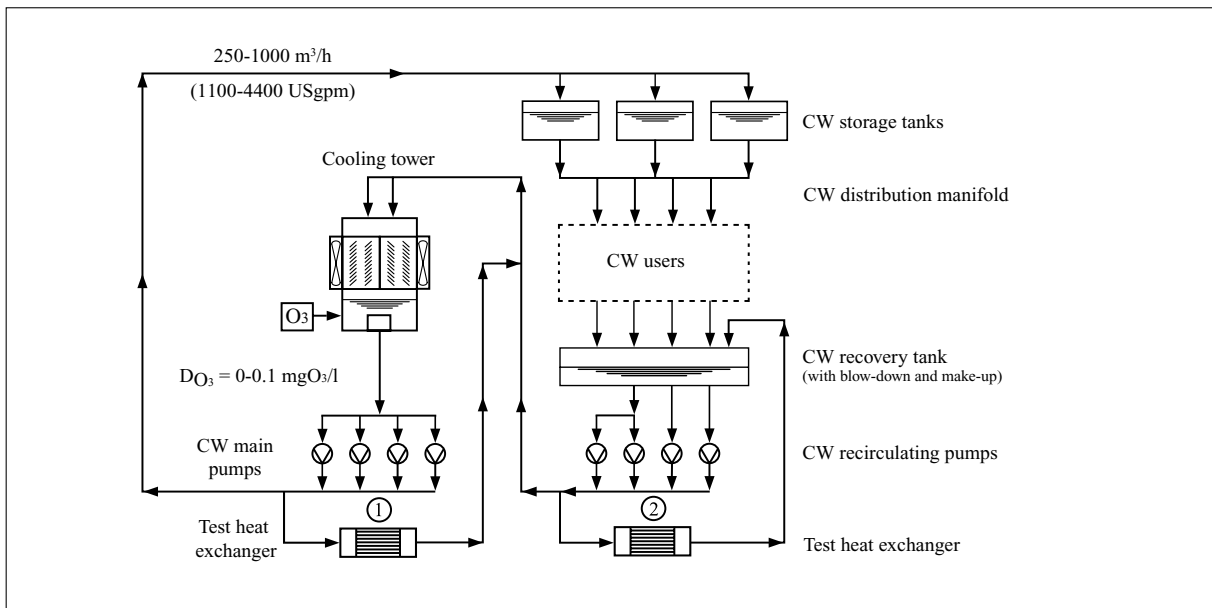

Figure 1: Cooling water system

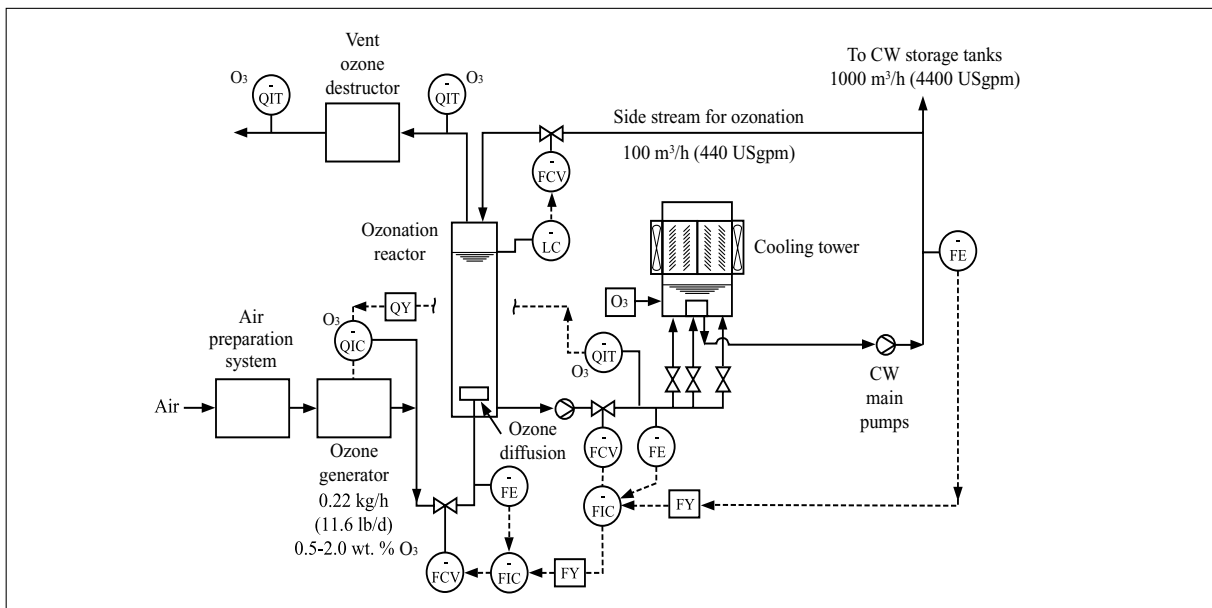

Figure 2: Ozonation system

Description of the Ozonation System

The ozonation system (Figure 2) is designed based on the principle of side stream cooling water flow ozonation. A portion of the cooling stream is diverted to the top of an ozonation tower. The side stream is then recovered from the bottom of the ozonation tower and fed back to the cooling tower bottom tank and mixed with the main cooling water flow.

The ozone is generated in a medium frequency ozone generator, with dry air as carrier gas, and then diffused into the cooling water side stream at the bottom of the ozonation tower. The off-gas is recovered at the top of the ozonation tower. The theoretical flow pattern is countercurrent flow, allowing for optimum ozone transfer from the gas phase to the liquid phase. Instruments, valves and controllers regulate and modulate the gas and cooling water flows as well as the ozone concentration.

Characteristics of the Complete System

Main cooling water flow:	200 – 1000 m ³ /h (880 – 4400 US gpm)
Thermal capacity:	7500000 kcal/h (1791000 Btu/h)
Make-up water:	100 m ³ /d (26000 US gpd)
Blow-down liquor:	65 m ³ /d (17000 US gpd)
Cooling water temperature:	ca 20°C (68°F) all year long (after cooling tower)
Ozone generator capacity:	0.22 kg/h (11.6 lb/d)
Concentration:	0.5 – 2.0 wt% O ₃
Feedgas:	Air
Power:	ca 3.0 kW at mains
Ozone absorption efficiency in the ozonation tower:	93 – 96%
Average ozone dose ref. to the main cooling water flow:	0.045 – 0.10 mg O ₃ /l
Ozone residual in side stream cooling water flow, before discharge into cooling tower base tank:	0 – 1.0 mg O ₃ /l
True ozone dose in main cooling water flow at pump sump:	0 – 0.1 mg O ₃ /l

Cooling Water and Make-Up Water Quality

The quality of the cooling water and make-up water was measured twice a week. The average values are shown in Figure 3. Among other interesting things, one can point out the following differences between the cooling water and the make-up water:

- Basically, as expected, all parameters analyzed show a higher concentration in the cooling water.
- Conductivity: The cooling water shows a conductivity 1.4 times higher than that of the make-up water. Accordingly, the chloride content and the hardness are also higher.
- Zinc, Iron, Copper: The increased values in the cooling water are probably the result of corrosion.

- **KMnO₄ Demands:** The equal values are an indication that some oxidation with ozone takes place.
- **COD:** The higher value in the cooling water indicates that some KMnO₄ resistant organics are accumulating in the system, mainly the antiscalant (phosphonic acid).

Parameter	Units	Cooling Water	Make-Up Water
pH	-	7.6	9.8
Conductivity	µS/cm	1400	1000
Suspended Solids	mg/l	2	5
KMnO ₄	mg/l	10	10
COD	mg/l	15	10
Chloride	mg/l	270	200
Sulfate	mg/l	180	150
Total Phosphate	mg/l	7	0.5
Nitrate	mg/l	50	30
Silicate	mg/l	4	4
Total Ca + Mg	mg/l	5	4
Total Fe	mg/l	5	4
Zinc	mg/l	120	10
Copper	mg/l	8	4
Antiscalant (Phosphonic Acid)	mg/l	50	4

Figure 3: Cooling water and make-up water quality (Av. values Dec. 15, 1988 through Dec. 28, 1989)

Test Heat Exchangers

Two identical shell and tube heat exchangers were installed, one on the cooling water side stream of the ozonated water immediately after the main cooling water pumps, the other on the side stream of cooling water without ozone residual, after the cooling water recirculating pumps (Figure 1). Each exchanger was fitted with 8 tubes of different materials which are typical for cooling circuits in process plants (Figure 4). The purpose of this test was to analyze the behavior of the various materials with respect to corrosion and scaling in water with and without ozone residual.

#	Material Type	DIN	ASTM	C	Cu	Zn	Ni	Al	Sn	Fe	As	Co	No	Ti
1	CuZn28Sn	2.0479.19	-	-	70.6	28.3	-	-	1.08	0.03	0.026	-	-	-
2	CuZn20Al	2.0460.19	-	-	76.6	rest	-	2.05	-	0.03	0.026	-	-	-
3	CuZn20Al1Ni	2.0460.1	-	-	76.8	rest	0.93	2.01	-	0.02	0.06	-	-	-
4	X5CrNiMo17 12 2	1.4401	316	0.07	-	-	12	-	-	rest	-	17.5	2.25	-
5	X5CrNiNo17 13 3	1.4436	316	0.07	-	-	12	-	-	rest	-	17.5	3.0	-
6	X1CrNiMoNb 28 42	1.4575	-	0.015	-	-	3.0	-	-	rest	-	26	1.8	-
		-	-	-	-	-	4.5	-	-	-	-	30	2.5	-
7	SMO 254	-	-	0.02	0.7	-	18	-	-	rest	-	20	6.1	-
8	Titanium	3.7035	-	-	-	-	0.007	-	-	0.2	-	-	-	rest

Figure 4: Heat exchanger and tube materials

Operation

The cooling water system with the open cooling tower and the ozonation started operation on February 13, 1989 and was in operation, after some initial difficulties for approximately 2 years following are some key operational results for the period from February 1989 to January 1991.

Cooling Water Flow

The cooling water flow was very irregular with significant hourly and daily variations. Since this fact presented an operational problem for the automatic control of the side stream to be ozonated, it was decided to operate with a constant side stream of 30-40 m³/h (132-176 US gpm) a few days after the start of the system.

During the first 200 days of operation, the cooling water flow varied between 200 and 1000 m³/h (880-4400 US gpm) with an average value of 600 m³/h (2640 US gpm). After a plant shutdown of about 50 days, the average flow increased to 750 m³/h (3300 US gpm), the minimum flow never dropping below 500 m³/h (2200 US gpm).

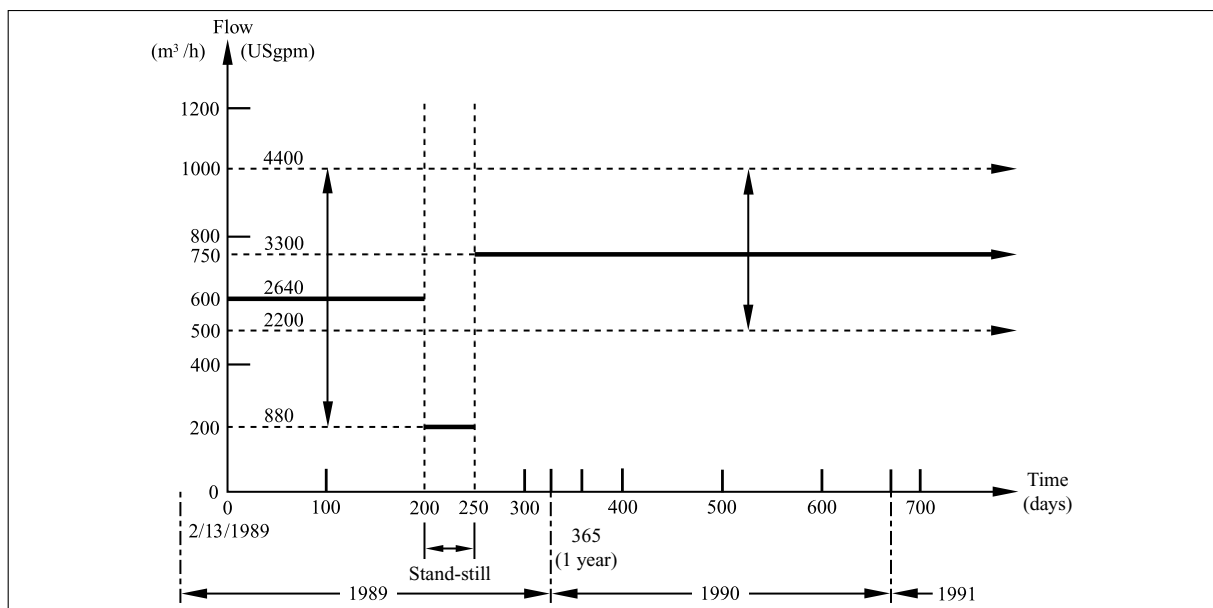

Figure 5: Cooling water flow

Cooling Water Temperature

The cooling water temperature all year long was at 20±2 °C (68±4 °F) after the cooling tower, and was practically not influenced by the make-up water (100 m³/d; 26000 US g/d).

Ozone Dose refers to the Total Cooling Water Flow

The ozonation system was set in such a way as to provide from the start an average ozone dose referring to the total cooling water flow of 0.045 mg O₃/l. It was not possible, because of the extreme variations

of the total cooling water flow (with pumps in and out of operation all day long) to adjust the ozone dose to momentary conditions of operation. This explains the rather broad range of instantaneous ozone doses. After 270 days, operational observations required the ozone dose to be increased (Figure 6). The average dose was set to 0.1 mg O₃/l. The reason why will be addressed in the following items of this report.

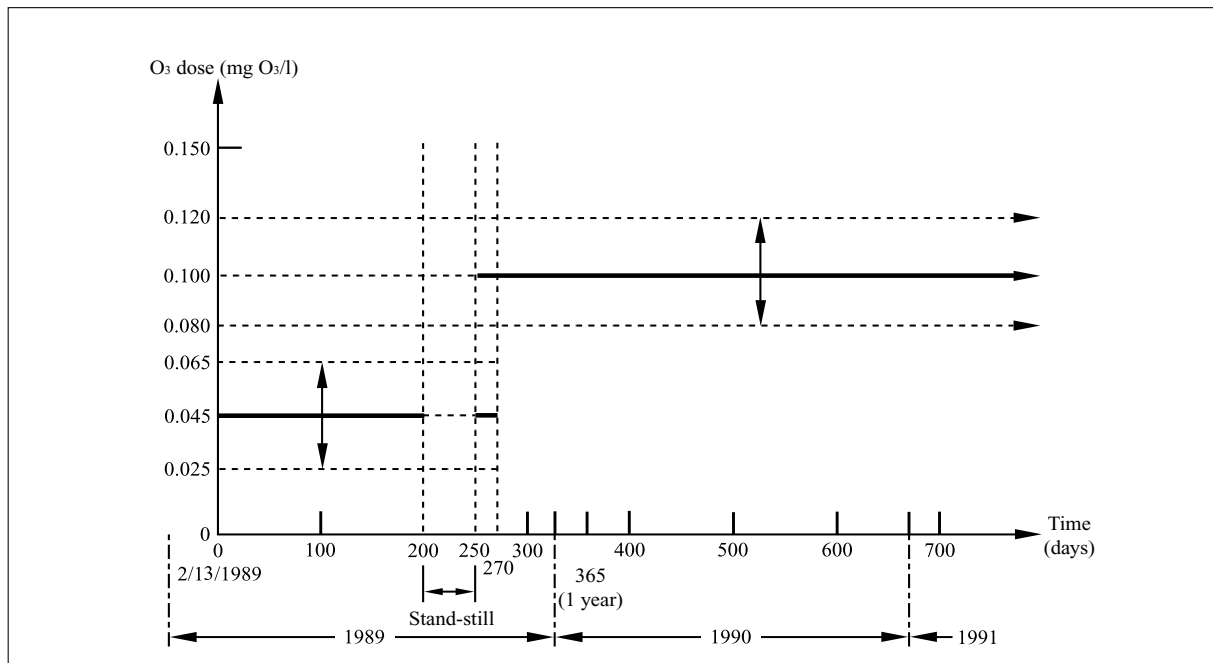

Figure 6: Ozone dose refers to the total cooling water flow

Side Stream Ozone Residual after the Ozonation Reactor

An important indicator that there is sufficient ozone residual in the main cooling water flow is the ozone residual in the side stream just before it is mixed with the main cooling water flow. This ozone residual must be controlled in an appropriate way, considering the ozone decay and consumption in the side stream during the time after it leaves the ozonation reactor and is blended with the main cooling water flow and the consumption of ozone by the main water flow due to impurities added by the open cooling tower and the make-up water. A careful analysis of the ozone half-life time is required after it leaves the ozonation reactor.

Figure 8 shows the effective ozone dose at the main cooling water flow in the pumping sump at the base of the cooling tower just after the ozonated side stream is blended and mixed with the main stream. The ozone dose is calculated based on the ozone production and the half-life time. The difference between these two values gives the ozone decay and consumption in the side stream, until the point where it is being mixed with the main cooling water flow. It does not, however, include any consumption of ozone by the main cooling water flow, due to chemical reactions.

We are dealing in this particular case with an open recycling system. The forced draft cooling tower can “pollute” the main cooling water flow with particles carried by the air and cause an additional ozone demand. This demand can be strongly variable over the years depending upon the geographical and environmental influence on the cooling system, factors like winds, airborne organics, sunlight, etc..

The cycles of concentration of the cooling system also have an impact on ozone consumption in the main cooling water flow. The smaller the cycles of concentration, the higher the amount of make-up water and the higher the ozone demand.

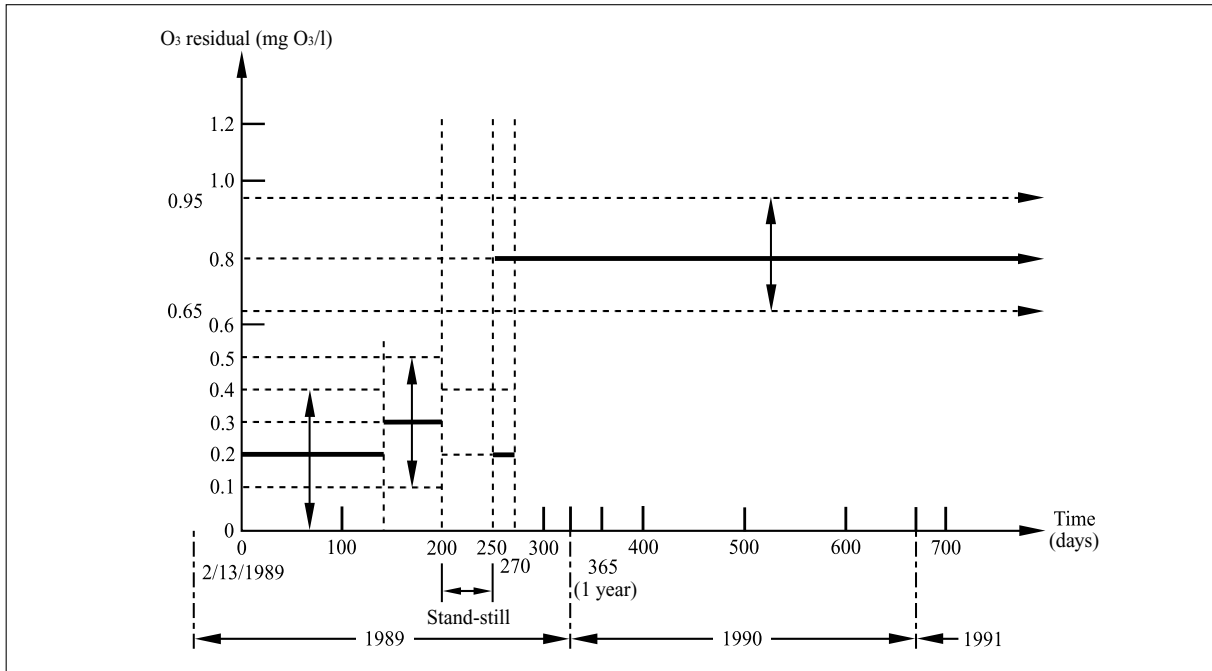

Figure 7: Ozone residual in the sidestream after the ozonation reactor

Ozone Residual in the Main Cooling Water Flow

The ozone residual in the cooling water flow was measured (Indigo Blue) in the main cooling water pump sump with the following results:

- Not detectable until operation day 270, when the average ozone dose was doubled
- Detectable, average approximately 0.03 mg O₃/l from operating day 270

After the main cooling water pumps, the ozone residual in the main cooling water flow is at the lower detection level of the chemical method applied (Indigo Blue), i.e., in the range of 0.01 mg O₃/l. Ozone has already reacted at that point with the “pollution” coming from the cooling water and the make-up water which feeds the system.

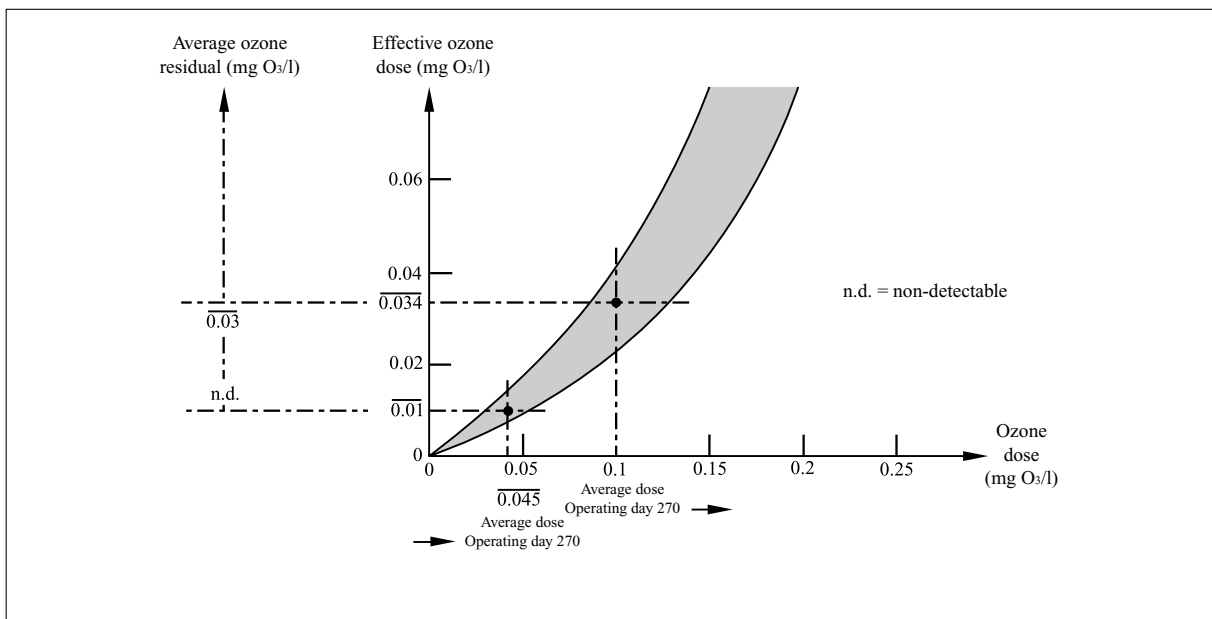

Figure 8: Main cooling water flow, effective ozone dose, ozone residual

Biofouling in the System

After 11 and 22 months of operation, inspection and observations were performed on both the cooling water system, essentially the cooling tower, and the 2 test heat exchangers. The results of the reviews were as follows:

Cooling Tower

After 11 months of operation:

- Water wetted parts, for example, base water collecting tank
 - No biofouling
- Aerated parts, parts in contact with daylight
 - Growth of green algae
 - No change with respect to operation before ozonation
- Top of cooling tower
 - Same green growth as before ozonation

No significant changes after 22 months of operation

Test Heat Exchangers

After 22 months of operation:

- Exchanger 1 with ozonated water showed a slight biofilm that was 26-30 times thinner than the biofilm in exchanger 2 with no ozone in the water

Corrosion Behavior

The corrosion behavior was checked after 11 and 22 months of operation for both the cooling tower and the two test heat exchanges, with the following observations:

Cooling Tower

After 11 months of operation:

- No change with respect to the operation before ozonation

After 22 months of operation:

- No significant change

Test Heat Exchangers

After 27 months of operation:

- The corrosion behavior of exchanger 1 with ozonated water is somewhat better than that of exchange 2

Conclusion

After 22 months of operation with ozone as biocide, the people who observed and analyzed the cooling system with open cooling tower at this power station drew the following conclusion (translated from German):

The tests and experiments carried out proved that ozone, applied at the selected dosages on a continuous basis for the treatment of cooling water is:

- Technically feasible
- Makes sense ecologically

- Is an excellent biocide
- Does not promote noticeable changes in corrosion behavior of the materials used

We considered it possible, therefore, to apply ozone as a biocide for the control of the growth and deposit of organic matter in cooling systems with capacities up to 60000 m³/h (264000 US gpm).

Key Words

Ozone; Cooling Water; Power Station Cooling Water Treatment; Scaling Control; Corrosion Control.

References

1. WELLAUER, R., ABB, Intermediate Report on the Heilbronn Pilot Plant, Germany 1990, (Internal Report)
2. ABB, Mannheim, Final Report "Environmentally Harmless Biocide Treatment of Open Cooling Water Systems with Ozone", part: Material Corrosion Behavior Analysis, January 1991, (Internal Report)
3. WELLAUER, R.; OLDANI, M., "Cooling Water Treatment with Ozone", Ozone: Science & Engineering 12(3):243-253 (1990)

Résumé

Le présent exposé décrit les résultats d'un traitement à l'ozone de l'eau d'un système de refroidissement. Il s'agit d'un circuit ouvert constitué des éléments suivants:

- Pompes principales
- Réservoirs de récupération
- Réservoirs principaux
- Tuyauterie de distribution vers les utilisateurs
- Pompes de recyclage
- Tour de refroidissement

Le circuit de refroidissement en question a une capacité de 1000 m³/h (4400 US gpm) et sa fonction est celle d'un circuit auxiliaire d'une usine de chauffage située en Allemagne.

Le système d'ozonation a été mis en service au début de 1989 et son fonctionnement a été suivi pendant plus de deux ans. Les éléments suivants ont été analysés et évalués pendant cette période:

- Résiduel de l'ozone dans l'eau
- Qualité de l'eau de refroidissement
- Dépôts organiques sur les surfaces de l'équipement et de la tuyauterie
- Comportement des matériaux du point de vue de la corrosion

Pour l'étude de la corrosion, deux échangeurs de chaleur similaires, équipés de tubes avec matériaux divers, ont été installés. L'un des échangeurs est en contact avec de l'eau ozonée alors que l'autre est traversé par de l'eau sans ozone.

Les résultats obtenus après deux ans d'opération sont très positifs et encourageants et le propriétaire du système de refroidissement a décidé de maintenir l'installation d'ozone en service pour le futur.

Zusammenfassung

Diese Arbeit fasst die Betriebsergebnisse zusammen, die bei der Behandlung von Kühlwasser in einem offenen Kühlsystem gesammelt wurden. Dieses Kühlsystem umfasst folgende Elemente:

- Hauptkühlwasserpumpen
- Kühlwassersammelbecken
- Kühlwasservorratsbehälter
- Kühlwasserkreislaufpumpe
- Verteilung zu den Verbrauchern
- Kühlturm

Das hier vorgestellte System ist ein Nebenkühlkreislauf in einem Kraftwerk in Deutschland, mit einer Umlaufmenge von 1000 m³/h.

Der kontinuierliche Betrieb wurde im Frühjahr 1989 aufgenommen. Die Anlage war insgesamt mehr als zwei Jahre in Betrieb. Während dieser Periode wurden die folgenden Größen analysiert und interpretiert:

- Restozon im Wasser
- Organischer Bewuchs auf Wärmetauschern und Rohrleitung
- Qualität des Kühlwassers
- Korrosionsverhalten der Materialien

Um das Korrosionsverhalten zu untersuchen, wurden zwei Versuchswärmetauscher installiert, beide mit identischen Versuchsmaterialien versehen. Einer der beiden Wärmetauscher war restozonhaltigem Wasser ausgesetzt, der andere ozonfreiem Wasser.

Die Resultate dieses zweijährigen Versuchsbetriebes waren ermutigend. Die Bereitschaft der Betreiber, die Ozontechnologie zur Kühlwasserentwesung zu verwenden, ist vorhanden. Der vorliegende Bericht beschreibt die Betriebsergebnisse der zweijährigen Versuchszeit.

OZONIA

Ozonia around the world



Ozonia Ltd
Stettbachstrasse 1
CH-8600 Duebendorf
Switzerland

Tel. +41 (1) 801 85 11
Fax +41 (1) 801 85 01
E-mail info@ozonia.ch



Ozonia North America
491 Edward H. Ross Drive
Elmwood Park, New Jersey 07407
USA

Tel. +1 (201) 794 31 00
Fax +1 (201) 794 33 58
E-mail info@ozonia.com



Ozonia Triogen Ltd
Triogen House
117 Barfillan Drive, Craighton
Glasgow G52 1BD, Scotland

Tel. +44 (141) 810 48 61
Fax +44 (141) 810 55 61
E-mail info@ozoniatriogen.com



Ozonia OOO
Dobrolubova st., 7
Nizhny Novgorod, 603109
Russia

Tel. +7 (8312) 33 44 84
Fax +7 (8312) 34 25 89
E-mail ozonia@kis.ru



Ozonia Korea Co., Ltd.
2F, Jae-il Bldg, # 94-412
7 Ga Youngdeungpo-Dong
Youngdeungpo-Gu, Seoul, Korea

Tel. +82 (2) 2633 69 63
Fax +82 (2) 678 65 94
E-mail champ02@unitel.co.kr



Ozonia Bern
Stauffacherstrasse 130a
CH-3014 Bern
Switzerland

Tel. +41 (31) 333 10 41
Fax +41 (31) 332 72 75
E-mail Rjenny@compuserve.com



Ozonia Japan
Komahara Bldg. 4F, 5-17-2 Shinbashi
Minato-ku, Tokyo 105-0004
Japan

Tel. +81 (3) 34 37 54 52
Fax +81 (3) 34 37 54 57
E-mail jeanmarc_morange@csi.com



Homepage
<http://www.ozonia.ch>
<http://www.ozonia.com>
<http://www.ozonia.ru>

**Ozonia products are available in all countries over the world.
Please contact us to find out details of your representative.**